

Seen from the Outlet End

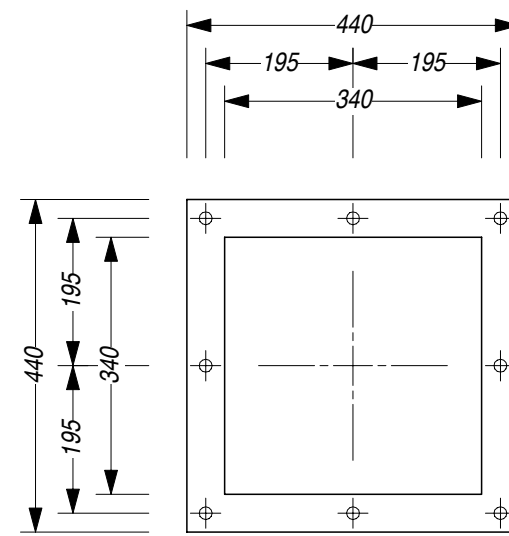

Flange on the Outlet End

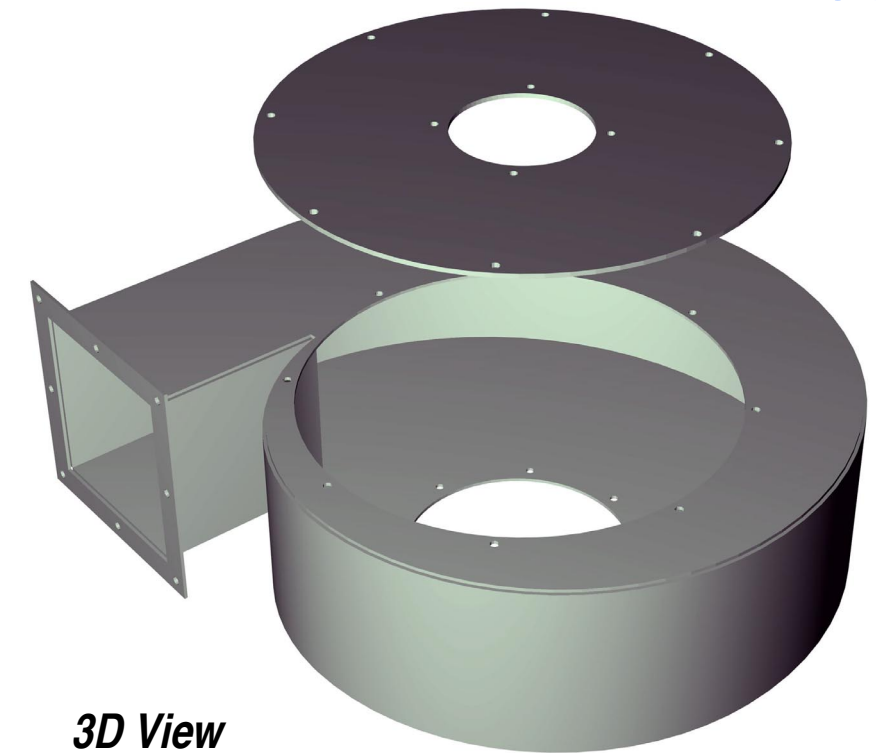

3D View

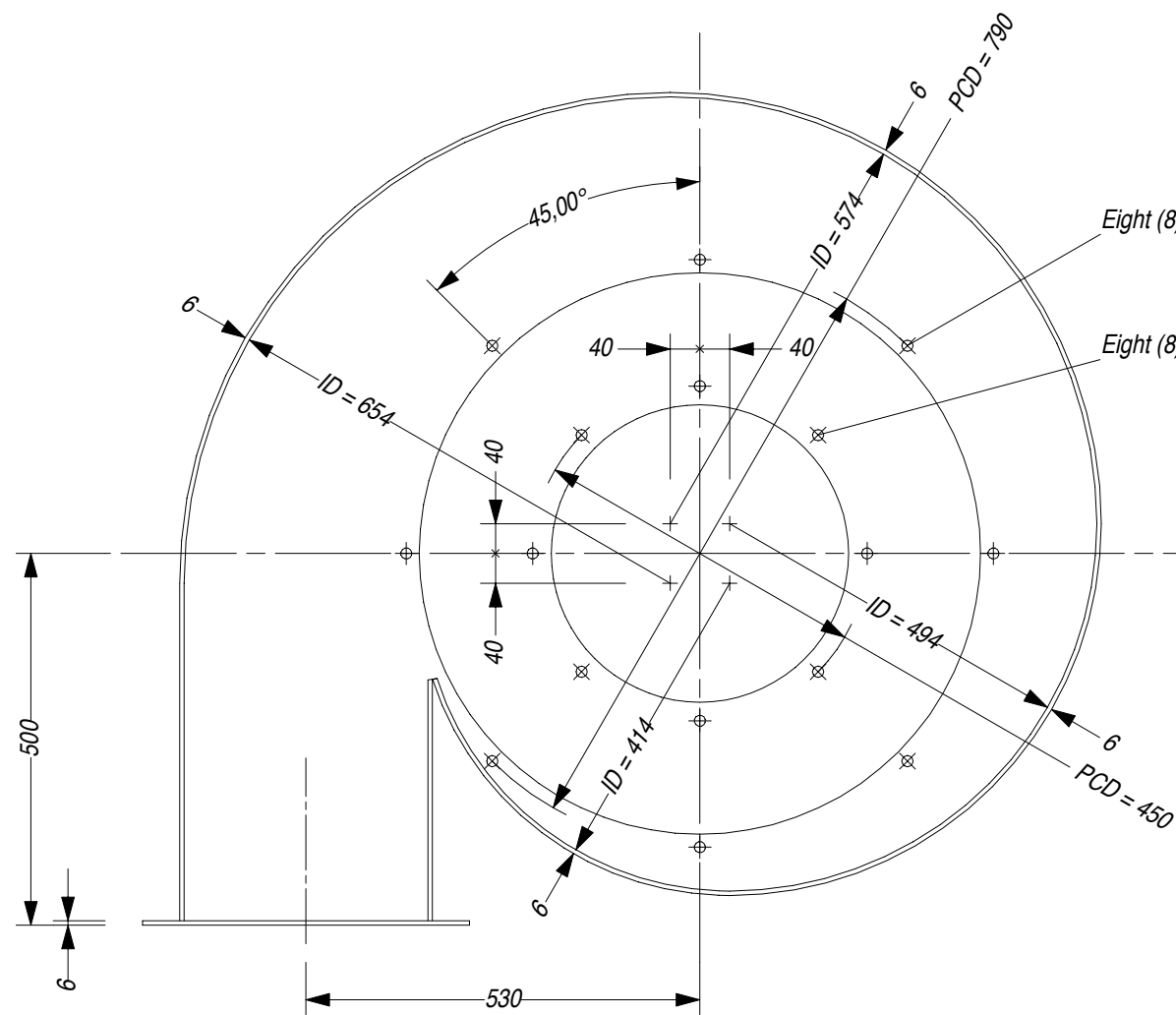

Top / Plan View

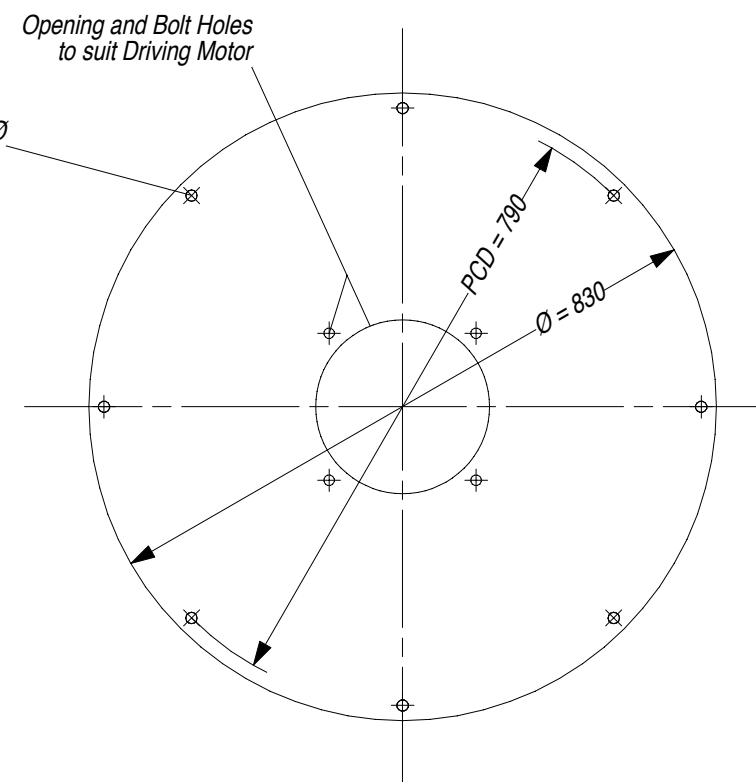

Top Plate - supporting Rotor and Motor
(see 3D View above right)

Material: Black Steel Sheet, 6 mm

Weight (finished): ~100 kg

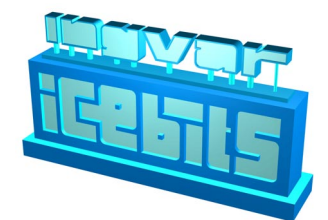

July 2004 - ingvar

LeanFish One

Exhauster - Housing

Scale: 1:10